

Feb. 4, 1964

G. E. HAGEN
FLYING APPARATUS

3,120,363

Filed Sept. 11, 1958

6 Sheets-Sheet 1

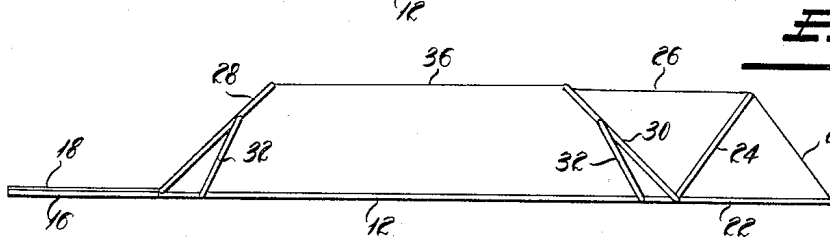
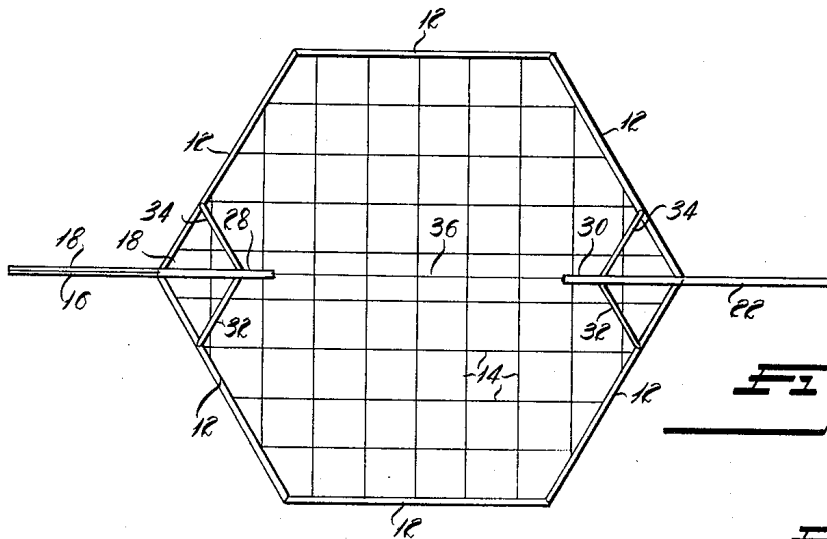
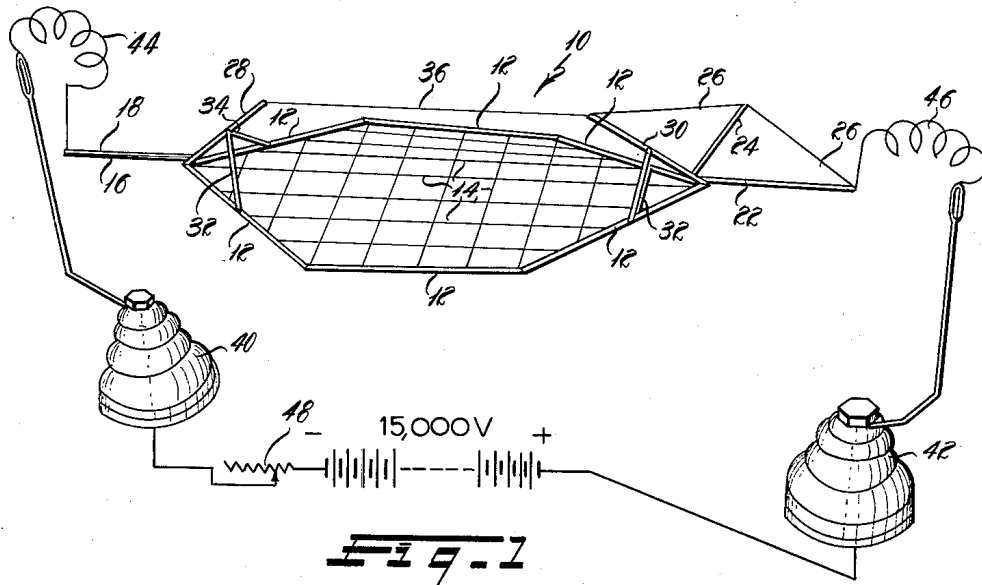

INVENTOR

GLENN E. HAGEN
Strauch, Nolan & Meale
ATTORNEYS

Feb. 4, 1964

G. E. HAGEN
FLYING APPARATUS

3,120,363

Filed Sept. 11, 1958

6 Sheets-Sheet 2

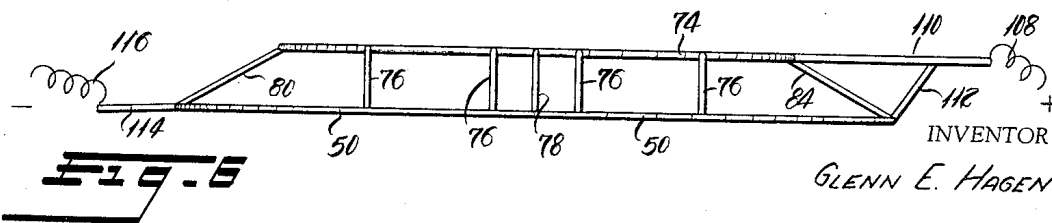
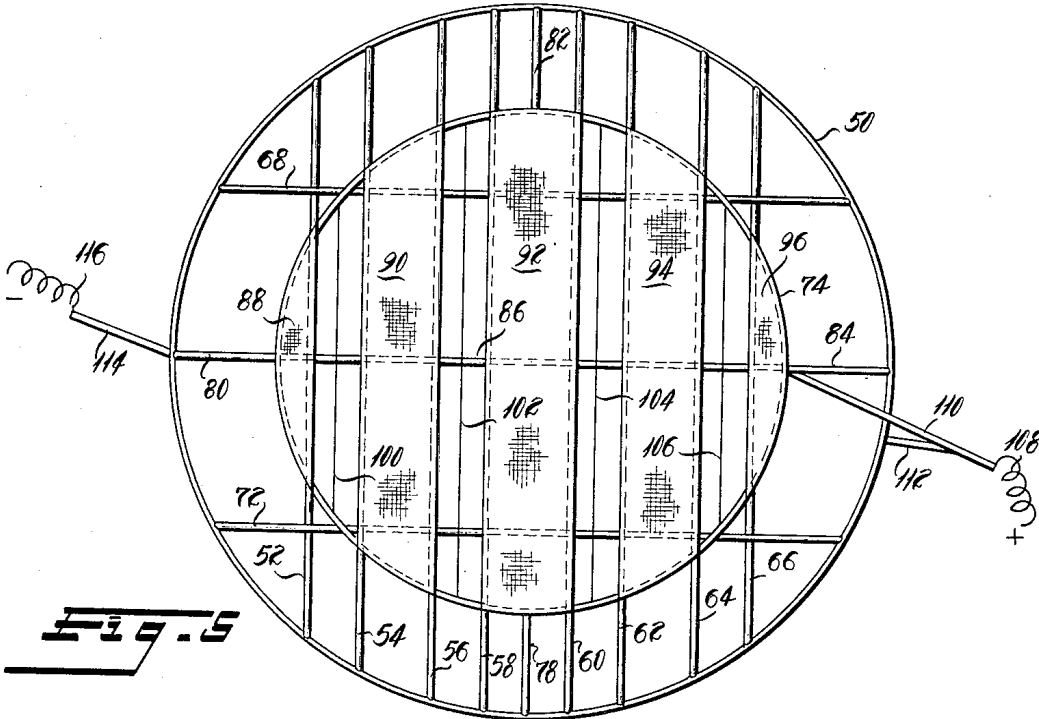
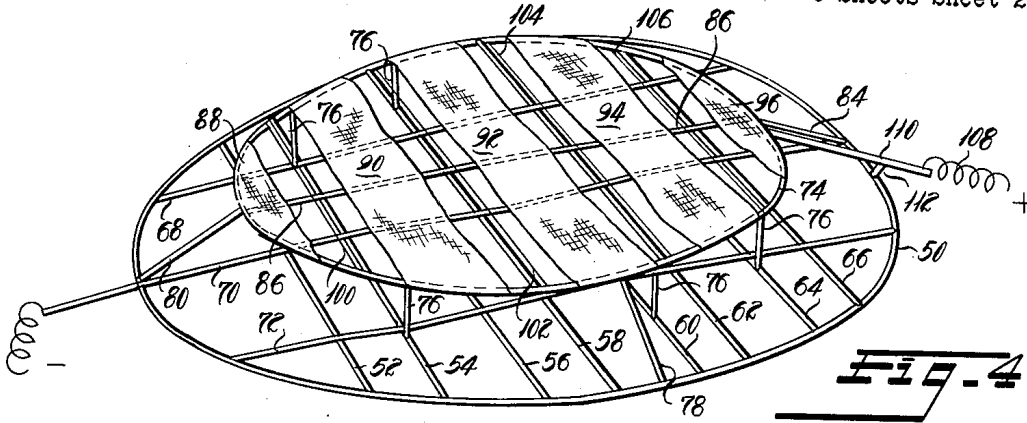

BY

Strauch, Nolan & Neale

ATTORNEYS

Feb. 4, 1964

G. E. HAGEN
FLYING APPARATUS

3,120,363

Filed Sept. 11, 1958

6 Sheets-Sheet 3

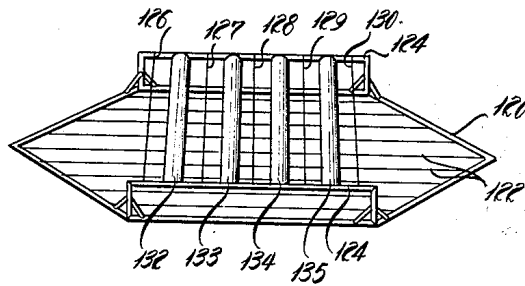

FIG. 1

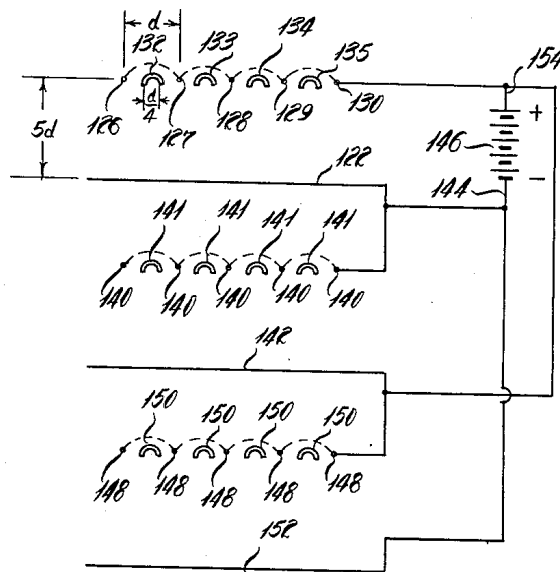

FIG. 2

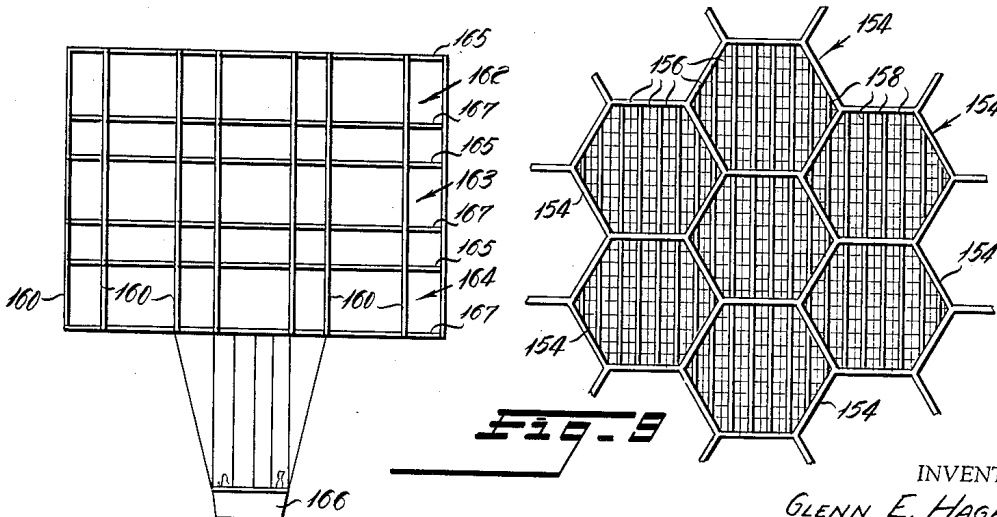

FIG. 3

FIG. 10

INVENTOR
GLENN E. HAGEN

BY

Stauch, Nolan & Neale

ATTORNEYS

Feb. 4, 1964

G. E. HAGEN
FLYING APPARATUS

3,120,363

Filed Sept. 11, 1958

6 Sheets-Sheet 4

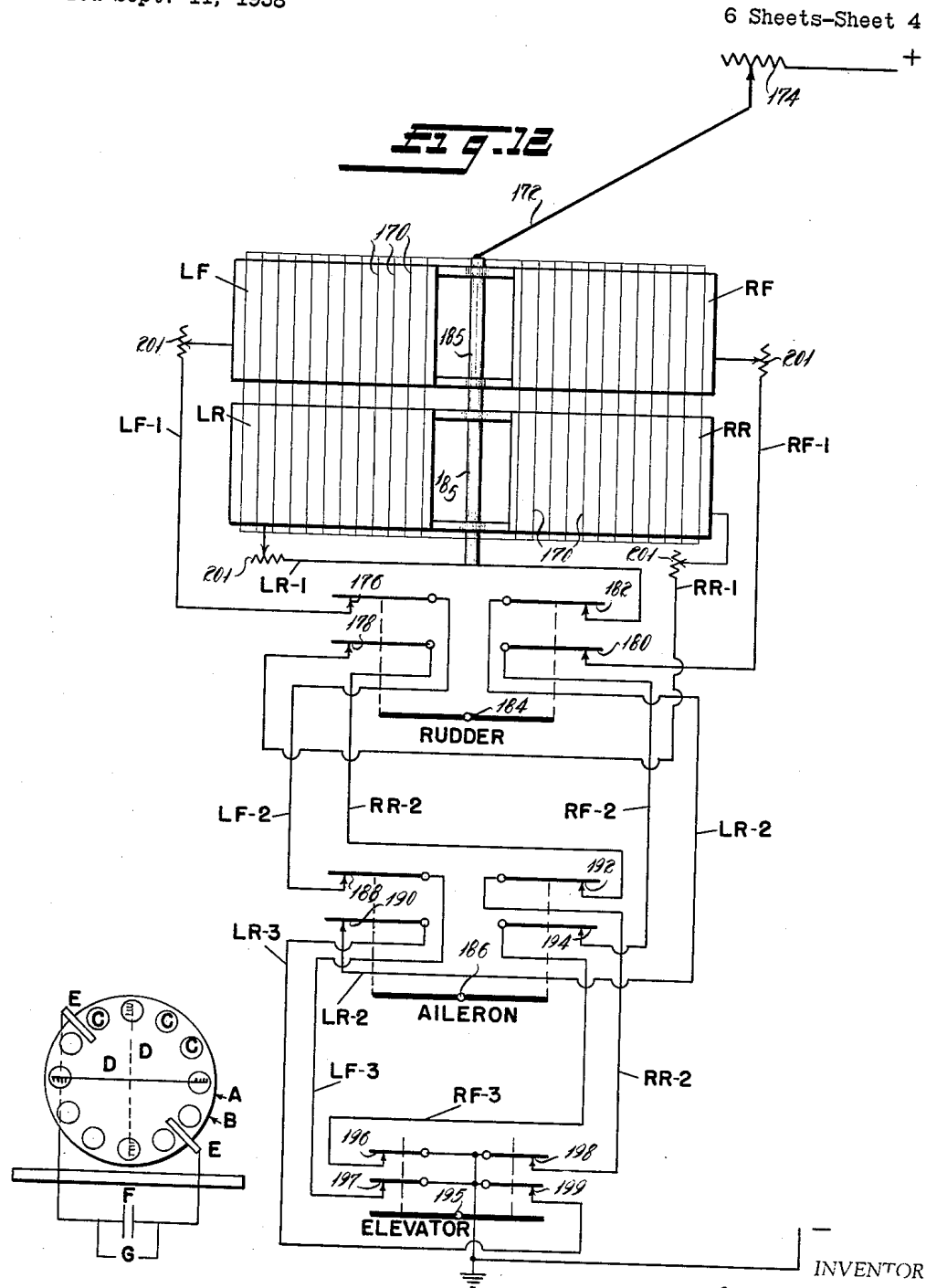

Fig. 12

Fig. 11

INVENTOR
GLENN E. HAGEN

BY *Strauch, Nolan & Neale*
ATTORNEYS

Feb. 4, 1964

G. E. HAGEN
FLYING APPARATUS

3,120,363

Filed Sept. 11, 1958

6 Sheets-Sheet 5

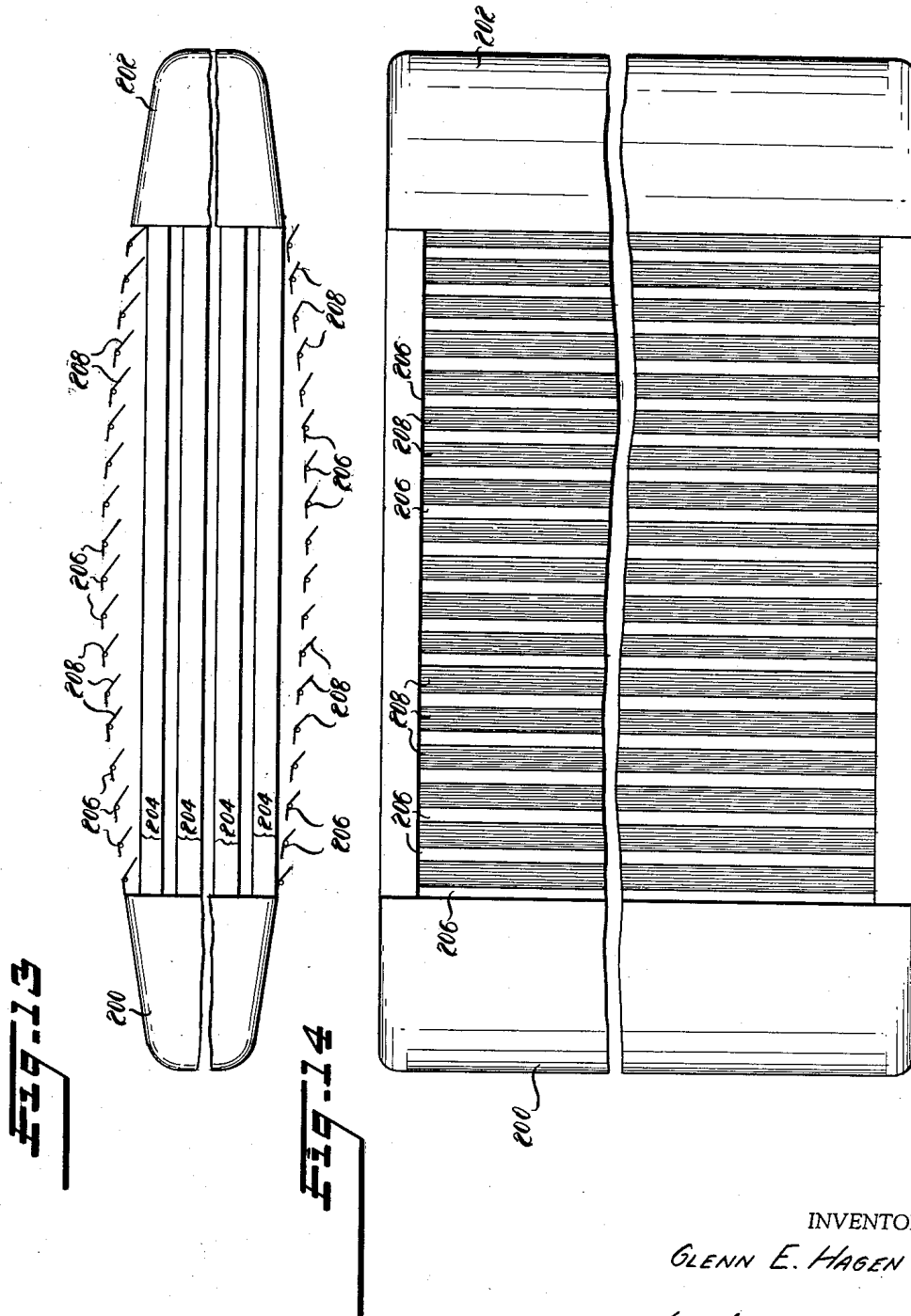

INVENTOR
GLENN E. HAGEN

BY

Strauch, Nolan & Neale

ATTORNEYS

Feb. 4, 1964

G. E. HAGEN
FLYING APPARATUS

3,120,363

Filed Sept. 11, 1958

6 Sheets-Sheet 6

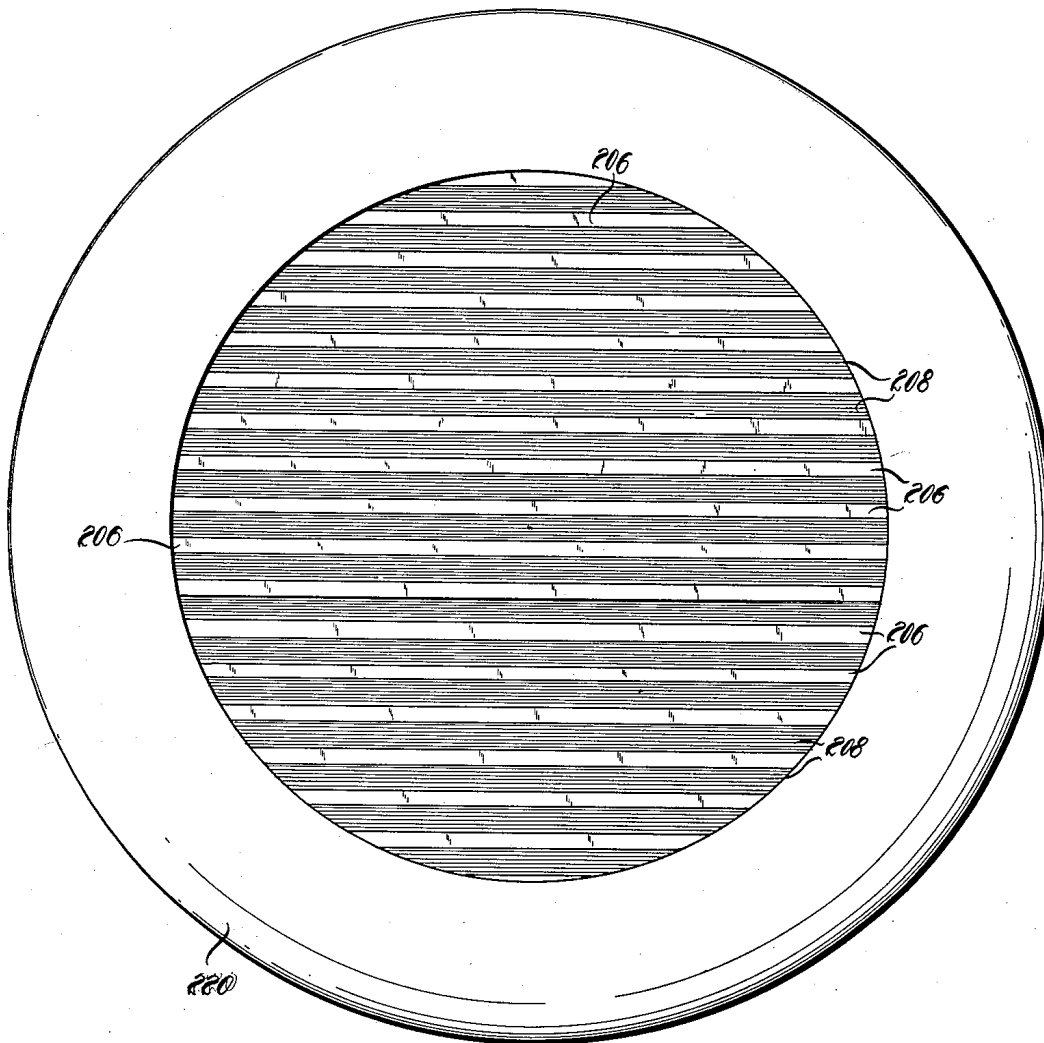

Fig. 15

INVENTOR
GLENN E. HAGEN

BY

Strauch, Nolan & Keale

ATTORNEYS

1

2

3,120,363

FLYING APPARATUS

Glenn E. Hagen, Fresh Meadows, N.Y., assignor, by mesne assignments, to Electronatom Corporation, New York, N.Y., a corporation of New York
 Filed Sept. 11, 1953, Ser. No. 760,390
 27 Claims. (Cl. 244-62)

This invention relates generally to heavier-than-air flying apparatus and methods of propulsion and control thereof. More specifically, this invention relates to such apparatus and methods utilizing reaction motors of the type operating on the principle of ionic discharge.

The apparatus of the present invention is similar in many respects to the conventional rotating wing helicopter in that both are capable of rising and falling vertically and of hovering, and have maximum theoretical horizontal speeds of the same general order of magnitude. The apparatus of the present invention may be characterized as being similar to a flying carpet in that structural rigidity is not essential and ripples in large horizontal surfaces are not objectionable.

The apparatus of the present invention, being of a light weight, open construction, is substantially independent of upward and downward air currents and because it may be constructed with open sides, it offers very little resistance to high atmospheric winds. The power required to maintain it in the air is, by comparison with other types of heavier-than-air craft, extremely low and is obtained from elastic molecular collision of the air fluid particles resulting from an ionic discharge.

The phenomenon of ionic discharge has been heretofore proposed for pumping vacua as is shown in U.S. Patent Nos. 2,460,175 and 2,636,664, and for generating wind as is shown in U.S. Patent Nos. 2,765,975 and 2,295,152. However, no one to my knowledge has utilized this phenomenon for causing acceleration of huge volumes of air controlled in such manner as to provide a flying craft of the character of my invention.

Accordingly, a principal object of the present invention is to provide a novel heavier-than-air craft which is propelled through the use of an electric discharge.

Another object of the present invention is to provide a novel means and method for producing and controlling motion of large masses of air through electric discharge for use as a reaction motor for propelling aircraft.

Further objects of the invention are to provide means and methods for improving the efficiency of the electric discharge reaction to increase the total lift capacity of the craft and for maintaining the electrical power supplied to a minimum, for stabilizing and steering the craft during flight and for gliding it to a safe landing in case of total electrical or power failure.

The invention itself, however, both as to its organization and method of operation as well as additional objects and advantages thereof will best be understood from the claims, and from the following description when read in connection with the accompanying drawings in which:

FIGURE 1 is a pictorial view of one embodiment of my invention;

FIGURE 2 is a top plan view of the embodiment shown in FIGURE 1;

FIGURE 3 is a front elevation view of the embodiment shown in FIGURE 1;

FIGURE 4 is a pictorial view of a second embodiment of my invention having a plurality of antenna wires;

FIGURE 5 is a top plan view of the embodiment shown in FIGURE 4;

FIGURE 6 is a front elevation view of the embodiment shown in FIGURE 4;

FIGURE 7 is a pictorial view of a further embodiment

of my invention having bias rods between the adjacent antenna wires;

FIGURE 8 is an elevation view in diagrammatic form of a multiple deck antenna and lifting grid arrangement;

FIGURE 9 is a plan view illustrating a preferred construction for a large area craft;

FIGURE 10 is an elevation view of a multiple deck craft with a suspended gondola;

FIGURE 11 is a diagrammatic illustration of a Wimshurst electrostatic generator utilized in supplying the propelling energy in one embodiment of my invention;

FIGURE 12 is an electrical circuit diagram illustrating a preferred method of stabilizing and steering a flying craft embodying the present invention;

FIGURE 13 is a side elevation view of a large flying craft embodying the principles of the present invention;

FIGURE 14 is a top plan view of the craft of FIGURE 13; and

FIGURE 15 is a plan view of a doughnut shaped craft embodying the present invention.

The craft 10 illustrated in FIGURES 1, 2 and 3 comprises basically a lifting frame composed of members 12 which are of a suitable lightweight material such as wood, aluminum, magnesium, or the like, secured together in the shape of a polygon as by an adhesive or other suitable fastening means depending upon the size and purposes of the craft, and all lying in a single plane. A grid of wires 14 of small diameter and thus of small weight is stretched between frame members 12. Wires 14 are all electrically connected together and connected to lead 18 which in the illustrated embodiment runs along spar 16 to be connected to one side of the power supply.

At the opposite end of the frame, a further spar 22 extends outwardly from frame members 12 in a substantially horizontal plane and a third spar 24 extends upwardly at an angle as shown in FIGURE 3. An antenna lead-in wire 26 extends from the outer end of spar 22, over the outer end of spar 24 and to the upper end of antenna support member 30 in such manner as to prevent sparking.

At opposite ends of the lifting frame, a pair of upwardly extending antenna support members 28 and 30 made of an insulating material such as wood, are provided and are secured at their lower ends to frame members 12 and supported by identical frames composed of members 32 and 34. The principal antenna wire 36 is stretched between the free ends of antenna support members 28 and 30 to be connected to lead-in wire 26 and insulated from grid wires 14.

The lifting frame composed of members 12 and collecting grid composed of wires 14 in an early experimental model which was successfully launched and demonstrated feasibility of the concepts was of the order of 4 inches by 6 inches in area and antenna wire 36 was about 2 inches above the lifting grid. The power supply for this model was similar to that used for generating the high voltage supplied to the picture tube in standard television receivers and contained an oscillator and output coil, a high frequency transformer and rectifier tube to develop about 15,000 volts. Potentiometer 48 was provided to vary the voltage applied between antenna 36 and grid wires 14 through insulators 40 and 42 and flexible pigtail leads 44 and 46. The diameter of the antenna wire 36 and grid wires 14 was 2.5 mils.

Analyzing the surprising performance and results attained by my invention, my improved aircraft receives its thrust from the momentum of air or other material being propelled backward or downward. The actual thrust or lift that it receives can be considered as being momentum per unit time, in other words

$$\frac{mv}{t}$$

3

whereas the investment of power necessary to provide this momentum is energy per unit time or

$$\frac{\frac{1}{2}mv^2}{t}$$

where m is the mass of the air, v is the velocity of the air and t is time. As the ratio of thrust or lift per unit of power is proportional to

$$\frac{2}{v}$$

from the foregoing two expressions, the efficiency of the reaction is inversely proportional to the velocity of the propelled air. I therefore utilize movement of very large masses of air at very low velocities, for example as low as ten miles or less per hour, and thereby achieve efficiencies which greatly exceed those presently obtained in the known existing aircraft designs.

A preferred method of moving very large masses of air at low velocities for propulsion of my improved aircraft comprises means for accelerating charged ions or particles and effective utilization of the apparent fact or theory that air molecules and ions are elastic (somewhat analogous to rubber balls) and lose their elasticity upon impact at higher velocities. I have found that the extent to which their elastic collisions are utilized determines the efficiency of the air movement and reaction process. Prior attempts to produce air ionization reactions with which I am aware have been based on production of high air velocities requiring intense ionization currents to develop high thrust. Under such prior conditions the molecular collisions are destructive and instead of acting like rubber balls with resultant multiplying air movement, the molecules act more like eggs, splattering to form chemical compounds, and secondary ionization which is the most harmful effect from the viewpoint of efficient thrust development. Molecules when striking each other at destructive impact velocities, will, at a minimum, knock off electrons. If the system utilizes positive ions in conjunction with a negative grid as the propelling force in one direction, then any negative electrons knocked off will immediately turn and go in the opposite direction. Whenever secondary ionization is present, forces exist, therefore, in both directions and the net result includes substantial energy losses and low thrust efficiency.

As I have demonstrated by numerous tests, one important aspect of the present invention is achieving highly efficient propulsion through ion collisions with relatively low potential gradients over large areas in a manner to move immense volumes of air at relatively low velocities by utilization of the multiplying effects of elastic molecular impact and rebound, and potential gradients such that the ions do not pick up enough energy in any one mean free path to cause excessive energy loss consummating in molecular disassociation or production of secondary ionization. Each positive ion apparently experiences a large number of collisions with separate molecules and particles during its trip between the antenna and the lifting grid where the ion then becomes electrically neutral. The larger the number of non-ionizing collisions which are guided by the voltage gradient in the space between the antenna and the lifting grid to be in the desired direction, the more effective the reaction becomes.

The embodiment shown in FIGURE 1 illustrates my first test assembly of a small craft of toy size I propelled from a supporting surface adjacent the floor to the ceiling in the test room, to the end of the flexible pigtail power supply coils 44 and 46 through variation of the potential produced by the 15 kv. power supply as by the adjustment of potentiometer 48. With a spacing of about two inches between antenna wire 36 and grid 14, some lifting force due to molecular collision appeared at above 5,000 volts, at about 13,000 volts, the structure had lifted

4

itself into and became suspended in the air and at higher potentials it rose upward. This is of utility as a flying toy and clearly demonstrated the feasibility of my concepts for the much larger craft hereinafter disclosed.

5 Several different embodiments similar to that shown in FIGURES 1, 2 and 3 were constructed. As the size is increased, the voltage may be advantageously increased with a resulting gain in lifting force, but without corresponding increase in power since the losses for a given ion current remain approximately the same.

10 The principal loss region lies within a cylindrical volume having a high voltage gradient surrounding antenna wire 36 where a blue glow or corona discharge is noticeable. In this region random movement of particles and inelastic collisions subtract from the useful lifting force. The size of this region is a function primarily of the ion current in the antenna and is substantially independent of the voltage; for any given ion current, losses due to inelastic collisions in this region are nearly constant.

20 On the other hand, the voltage gradient decreases with an increase in distance outwardly from antenna wire 36 at a faster than linear rate. Thus as size and voltage are increased, I have found the efficiency in terms of lifting force per unit power input improves very rapidly.

25 The effect of corona discharge appears to be a principal source of loss in creating thrust by ionization. I have discovered that this loss can be reduced by changes in geometry and electric field patterns. Referring now to FIGURES 4, 5 and 6, a further embodiment of my invention is illustrated wherein the lower lifting frame is formed of a closed curved member 50 which may be formed of a lightweight metal, such for example as aluminum, having its ends suitably secured together. In practice, a long piece of aluminum wire or rod may be bent into a substantially circular shape and the ends welded together. A series of aluminum cross rods 52, 54, 56, 58, 60, 62, 64 and 66 extends in a substantially parallel relationship across from one side to the other of lower frame curved member 50. At right angles to cross rods 52-66 are cross rods 68, 70 and 72, and each cross rod is suitably secured to the other cross rods it contacts and to curved member 50 to provide a base skeleton.

30 While the grid of fine wires similar to that shown in FIGURE 1 at 14 may be added, if cross rods 52-72 are spaced sufficiently close together, they may serve as the lifting grid. In one embodiment grid rods 52-72 were formed by cutting 1/8 inch aluminum tubing in half and mounting the cut tubes with the sharp edges down at positions about one inch apart. The purpose of using aluminum strips with the edges bent downwardly was to reduce secondary ionization that occurs at sharp edges.

35 Above curved member 50 is an upper frame composed of a similarly constructed curved member 74 which is rigidly supported above the lower frame as by means of a plurality of support bars 76 of insulating material secured at opposite ends between upper curved member 74 and respective ones of cross rods 54 through 64. To provide lateral support, four angularly disposed support bars 78, 80, 82 and 84 of insulation material may be provided to extend between lower curved member 50 and upper curved member 74.

40 The upper frame contains a rigid support member 86 extending diametrically across curved member 74 between the upper ends of support bars 80 and 84. A series of strips 88, 90, 92, 94 and 96 of a flexible material such as lightweight fabric as is used in the construction of parachutes is applied across upper frame curved member 74 for a purpose which will appear below.

45 Four separate antenna wires 100, 102, 104 and 106 are positioned between fabric strips 88, 90, 92, 94 and 96 and are connected in parallel to the positive terminal 108 on spar 110. Support 112 is provided between base member 50 and spars 110 to assure a minimum air gap between the lead-in conductor to antenna wires 100-106 and

75

5

the lifting grid to prevent sparking. On the opposite side spar 114 provides support for the connection to the negative power supply terminal 116. In this embodiment, as well as the one shown in FIGURES 1, 2 and 3, the location and length of the spars 110 and 114 were chosen to balance the craft as nearly as possible so that it would remain in a substantially level position in flight.

In the embodiment shown in FIGURES 4, 5 and 6, the total lifting power was increased significantly because of the use of four antenna wires with very little increase of input power. The fabric strips 88-96 reduced the interaction between adjacent ones of antenna wires 100-106 and served to funnel the downward passage of air at the region of the antennas. This increases the air velocity across the antennas and causes the ions to be carried away faster. Also, the fine wire used for the antennas vibrates as the air passes downwardly over the antenna wires thereby facilitating the removal of the ions from the antenna.

With multiple antenna arrangements, the antenna current is preferably made as low as possible and maximum voltages are used to provide maximum efficiency. The low current is accompanied by a reduced corona discharge which was readily visible in a darkened room on some of the earlier designs, but which is not present in the presently preferred embodiments.

In the immediate region of the antenna, relatively high losses are present first because the ion spray is in random direction so that the net contribution to the lift is nearly zero and second, the electric field gradients are so high that inelastic impact and secondary ionization inherently occur. Thus, instead of only positive ions moving outwardly from the antenna, negative ions are also present which move inwardly toward the antenna resulting in collisions with loss of energy. As the ionizing current per unit length of the antenna is reduced, the region of high loss surrounding the antenna becomes smaller in diameter and consumes less of the applied potential. Thus, optimum design tends toward low antenna current and large geometry.

In the embodiment shown in FIGURES 4 through 6, the four antennas 100-106 ranged from about 6 to 8 inches each in length and the total current applied was about 50 microamperes at some 15,000 volts. This embodiment provides a substantially improved lift to power ratio over that of the embodiment of FIGURE 1, and further, provided sufficient lift to carry considerably more than its own weight.

Referring now to FIGURE 7, a further embodiment is illustrated which has a lifting frame 120 supporting a lifting grid 122 composed of a series of small wires and an antenna frame 124 of insulating material carrying antenna wires 126, 127, 128, 129 and 130. Between each pair of antenna wires, bias rods 132, 133, 134 and 135 are provided. Bias rods 132-135 are made of a conductive material such as aluminum and have a cross section shaped substantially in the form illustrated in FIGURE 8 with an upper curved surface so as to provide minimum resistance to air flow and rounded corners on the edges to minimize the likelihood of arcing.

The function of bias rods 132-135 is to draw ions away from the antennas rapidly in the general direction of the bias rods and to suppress electrical interaction between adjacent antennas. The downwardly directed air flow sweeps the ions on past the bias rods so that rods 132-135 do not themselves draw appreciable current. If the spacing between the antenna wires approached that of the lifting grid so that the craft became a symmetrical structure, no substantial lift would be provided. Bias rods 132-135 were at first connected to the main power supply through a separate potentiometer and the optimum voltage range determined. This was found to be about 10% less than the antenna voltage, and was difficult to keep at an optimum value by manual adjustment which indicated that a fairly narrow critical voltage range is pres-

6

ent. To facilitate adjustment, high value resistances were connected between bias rods 132-135 and lifting grid 122. However I found that the air resistance due to the spacing of the bias rods from the lifting grid could be used as a satisfactory resistance path. This reduced somewhat the difficulty of adjusting the bias rod voltage, and I then discovered that the desirable voltage could be obtained automatically and without any special circuit connection from the power supply by simply using the proper geometry whereby the leakage current between the antenna wires to the bias rods and from the bias rods to the lifting grid would provide the desired operating potential on the bias rods. Thus in practice the bias rods 132-135 are located so that the relative distances from the antenna wires and the lifting grid determine the bias voltage applied.

Referring now to the upper deck of a multiple deck craft diagrammatically illustrated in FIGURE 8, bias rods 132-135 are formed from aluminum tubing cut in half and having a diameter of about one quarter of the distance between adjacent antenna wires 126-130. The bias rods may be supported in substantially the same plane as the plane of the antenna wires and midway between adjacent antenna wires. About five times the spacing between adjacent antenna wires provided effective spacing between lift grid 120 and the plane of the antenna wires 132-135.

The improvement in lifting efficiency provided by the bias rods has been found to be about 15% over an identical structure without bias rods. While the foregoing dimensions appear at present to illustrate optimum design ratios, it should be understood that they are primarily only illustrative as considerable variations both of voltage and physical dimensions are permissible and the choice of final dimensions is controlled to some extent also by the nature and characteristics of the high voltage power supply.

In the multiple deck arrangements, the deck beneath lifting grid 120 comprises an antenna means having antenna wires 140 separated by bias rods 141 and a lifting grid 142. The antenna wires 140 are all connected to the negative terminal 144 of power supply 146 to alternate the polarity of the ions for the adjacent decks. This eliminates any interaction between lifting grid 122 of the upper deck and antennas 140 in the adjacent lower deck. While the lifting efficiency of a deck having negative power supplied to the antennas is reduced some 10 to 20% from the efficiency achieved with a positive potential applied to the antennas, nonetheless in the multiple deck structures such reversal of power supply terminals provides a greater lifting efficiency than would be obtainable with structures arranged to utilize a positive potential on the antennas of each deck.

The reason for the difference of lifting efficiency between a craft having positive voltage applied to the antennas and the same structure having negative voltage applied to the antennas is because the positive ion has about 20% lower mobility in air than does the negative oxygen or nitrogen ionized molecule formed when the antenna is negative. For maximum lift, ions having low mobility are preferred because they have a greater effect on the air molecules. In an electric field having a high voltage gradient or under high currents the negative ion tends to occasionally lose its extra electron to another molecule so that brief periods exist where such freed electrons travel alone at great speed and cause secondary ionization. However, large dimensions may reduce somewhat the difference in favor of using the positive potential on the antennas. This can be determined readily by tests of contemplated larger structures when available.

In FIGURE 8, alternate decks are illustrated as having the polarity of the applied voltage reversed so that the potential of lifting grid 122 is the same as the potential of antenna wires 140 in the next lower grid to thereby eliminate any upward attraction by grid 122 of ions produced by antenna wires 140. However, by placing a suitable

isolating grid between antenna wires 140 and lifting grid 122 to neutralize the electric field therebetween, the antenna wires 140 for the lower deck may also be connected to the positive terminal of the power supply. The electric field may be neutralized by connecting the isolating grid to the same potential as the next adjacent lower antenna wires are connected. With isolating grids (not shown) beneath and suitably spaced from each lifting grid to avoid interference with operation of the deck next above, all the antenna wires for each of the decks of a multi-deck craft may be connected in parallel to the positive terminal of the power supply.

In any one deck, ions of only one polarity can be used effectively because if both negative and positive ions are present, the two polarities will go in alternate directions. If alternating currents were used, the frequency would have to be so low that ions of one polarity would have to be completely cleared out before ions of the other polarity are introduced. Since the mobility of the ions is so low, the use of alternating voltages at atmospheric pressures adjacent the earth's surface in dense air is not desirable. However, in view of the reduced molecular density at high altitudes where the air pressure is greatly reduced, the use of alternating voltages at high altitudes may not be precluded.

Referring again to FIGURE 8, a third deck may be provided beneath lifting grid 142 which comprises antenna wires 148 and bias rods 150 and a lifting grid 152. The positive terminal 154 of power supply 146 is connected to antenna wires 148 to the lifting grid 142 of the immediately adjacent deck above, and negative terminal 144 of power supply 146 is connected to lifting grid 152.

Any desired number of decks may be stacked vertically on top of each other. For reasons pointed out above, it is preferred that alternate decks be connected in parallel to the power supply and that adjacent decks be connected to have opposite polarities on the antenna wires to thereby obviate the use of special neutralizing grids. The minimum distance between decks is about 8 inches and a minimum distance between the lifting grid 142 of one deck and the antenna wires in the assembly of the next lower deck is about 3 inches. Considerably larger spacings may be preferred with operating voltages upwardly to 60 kc., but are not critical.

A craft in accordance with the present invention which is adapted to carry its own power supply and a payload may be composed of a large area skeleton designed to provide maximum strength to weight ratio. Such designs may for example, be similar to the well-known honeycomb construction as shown in FIGURE 9 wherein each hexagonal frame section 154 is related to the adjacent sections so as to have as many common sides as possible. The frame may be made of a lightweight metal with the lifting grid wires 155 shown directed in FIGURE 9 directed horizontally on the sheet, stretched between and secured to the several frame members so that in the event of wire breakage only a small section is affected. Antenna wires 156 and bias rods 158 are shown in FIGURE 9 as being directed vertically on the sheet.

Vertical support members 160 of an insulation material are provided between decks 162, 163 and 164 as is shown in FIGURE 10 for supporting the antenna and bias rod assemblies 165 at positions between the several lifting grids 167. By the foregoing type of modular construction, large crafts may be constructed of substantially any desired configuration and the larger the horizontal size, the more efficient the discharge reaction becomes.

Updrafts and downdrafts as well as side winds have a barely perceptible influence on a framework structure as shown in FIGURES 9 and 10 and therefore the craft of the present invention is not subjected to the strain presented by lighter-than-air dirigibles which present broad surfaces to ambient air currents and wind in all three directions.

A gondola 166 may be suitably suspended beneath the

decked honeycomb structure of FIGURE 10 and carry the prime mover, electrostatic generator and apparatus for guidance. In view of the very small power required, several lightweight prime mover motors, such for example as are used for flying model airplanes, may be used to drive a plurality of electrostatic generators connected in parallel to serve as a self-contained power supply for a relatively low-cost test unit. In the case of the contemplated very large craft, larger power equipment will of course be used.

Electrostatic generators such as the well-known Wimshurst Machine shown in FIGURE 11, which comprise two glass disks, A and B, rotated close together and in opposite directions and contain a number of tin or aluminum foil carriers C upon the outside surface of each plate may be used. Neutralizing conductors D are provided for each plate at right angles to each other. The collecting combs E are connected to condenser F across the terminals of which the output voltage is available. Several of such generators connected through rectifiers to a common power line may be used to supply electrical power to craft having substantial sizes. To date craft successfully flown have produced lifting forces of over 7 pounds per horsepower, and lifting forces per horsepower estimated to be on the order of 250 pounds per horsepower are indicated as available in larger sized craft. Therefore, with a structure having sufficient area, an operator and additional passengers or payload may be carried.

As is apparent from the embodiment shown in FIGURES 9 and 10, the lifting surfaces extend over an area which is limited only by structural considerations and since there is substantially constant and uniform lift throughout the volume of the craft, structural designs may deviate substantially from current practice. Rigidity is not an essential characteristic and the lifting grid theoretically may be a flexible structure in which ripples appear so long as highly concentrated ionic discharge areas are avoided. Large structures having insufficient strength to be self-supporting without the presence of lift power may be assembled on scaffolds which are removed after the craft is completed and power is applied. Two or more small motors with or without separate generators are supplied to enable the craft to hover while at least one motor is shut down for maintenance or replacement purposes.

Stabilization and control of the craft of the present invention may be effected through independent control of the ionization current in separate regions as by dividing the lifting grid into four electrically separate regions designated LF, RF, LR and RR in FIGURE 12. All the antenna wires 170 may be connected to a common lead 172 which extends to the positive terminal of the power supply through a variable resistor, such for example as series potentiometer 174. Lead LF-1 extending from the left forward region LF and lead RR-1 extending from the right rear region RR are connected to separate variable impedances, which because of the high voltage and low current utilized, may be in the form of needle point contacts 176 and 178 which effectively add resistance in the lead as the air gap spacing between movable contacts is increased.

Lead RF-1 from the right front region lifting grid RF and lead LR-1 from the left rear region lifting grid LR are connected to similar separate variable impedances provided by varying the air gap spacing between contacts 180 and 182 respectively. A rudder control element which may be supported for pivotal movement about point 184 to be similar in operation to the rudder control in a conventional airplane is provided to add resistance concomitantly at contacts 176 and 178 or at contacts 180 and 182 to cause opposite corners of the craft to bend downwardly since the craft of the present invention may be very flexible. This then produces a

thrust having a horizontal component to turn the craft counterclockwise or clockwise while hovering.

In an embodiment where the lifting frame is rigid, the front regions LF and RF and the rear regions LR and RR may be mounted about a central pivot axis, such for example as rod 185, in such manner that a limited angle of tilt is provided to introduce a component of force tending to move the craft laterally. If the front sections pivot with section RF moving downwardly about axis 185, the lateral component of force is to the right; if the rear sections pivot with section LR moving downwardly about axis 185, the lateral component of force is to the left, and the resultant rotation is clockwise as viewed from above.

The aileron control pivots about pin 186 to open contacts 188 and 190 or to open contacts 192 and 194 thereby adding resistance to leads LF-2 and LR-2 or to leads RF-2 and RR-2 respectively. The added resistance decreases the applied voltage and the current through the corresponding regions on the left or the right side of the craft to lower the left or the right side. Assuming a construction not utilizing the pivotal movement about axis 185, this will tilt the craft depending upon the direction the aileron control is moved.

The elevator control pivots about pin 195 to control the opening of contacts 196 and 197 or contacts 198 and 199 and in a similar manner lowers either the front or the rear of the craft by reducing the voltage and current supplied to the respective front or rear regions. The rudder, aileron and elevator controls may be wired in series and connected to the common negative terminal of the power supply which is preferably grounded thereby simplifying insulation problems.

Stabilization of the craft is comparatively simple and may be effected by variable resistances 201 in each of leads LF-1, RF-1, LR-1 and RR-1. Individual adjustment, which may be made manually or automatically, of resistances 201 may be used to balance the lift of each quadrant of the craft.

Referring now to FIGURES 13 and 14, a further embodiment of the craft is illustrated having a forward enclosed compartment 200 and rear compartment 202 with a plurality of decks 204 of lifting grid and antenna assemblies located centrally of the craft. The decks of lifting grid and antenna assemblies may be constructed similarly to the arrangements shown in FIGURES 7-10 and provided with a stabilization and guidance system as illustrated in FIGURE 12. The side walls in the vicinity of grid decks 204 are preferably open, but may be covered with a lightweight foil if desired.

In accordance with one feature of this invention, the upper and lower surfaces of the craft are covered with an air foil 206 which blends in with the surfaces of the fore and aft compartments 200 and 202. Flaps 208 on the upper and lower surfaces are hinged to open downwardly as illustrated under the influence of gravity and to swing freely open in event a severe updraft is encountered, to automatically protect the craft against upward air currents.

When the craft is hovering the downwardly directed air current will cause flaps 208 to assume open position as illustrated, with little resistance to the downward air flow across the lifting grids.

Upper and lower flaps 208 may be of well-known stream lined shapes and are preferably, although not necessarily, provided with means (of which a variety will be apparent to those skilled in the art and therefore not here shown) for adjustably controlling the maximum open flap positions to control of rate of descent in event of power failure, and the rate of forward movement. To cause forward movement, the lower flaps 208 are squeezed almost closed leaving open narrow slots directed backwards so that the normally slow downward stream of air is converted by those flaps into multiple variable relatively high velocity blasts directed to the rear, the re-

action of which causes the craft to move forward depending upon the air blast velocity and resultant forward reactive thrust. Also flaps 208 on the upper surface properly streamlined, when almost closed, provide in effect wing slots which have been shown to lead to very efficient air dynamic lift because they keep pulling the turbulent air layer off the upper surface resulting in a more nearly laminar flow.

Forward movement may be started by dropping forward end 200 and may be stopped by lowering the rearward end 202 by means of the elevator control shown in FIGURE 11. As the nose end 200 drops, the air flow through flaps 208 on the lower surface inherently produces forwardly directed thrust. The air speed along the lower surface foils 206 inherently tends to close flaps 208 on the lower surface to add further to the forward thrust.

While maximum air velocities with the single deck models is relatively low, as for example, of the order of 10 miles per hour, the velocity from multi-decked structures may be made considerably higher, particularly when forced through slotted openings of reduced size when flaps 208 on the lower surface are substantially closed. However, maximum practical horizontal speed is expected to be limited to speeds of the order of about 200 to 250 miles per hour. At such speeds, the lift may be obtained principally by aerodynamic means and the ionic discharge system may then be used primarily as a forward propulsive system.

While rotating wing aircraft such as helicopters must stay tilted forward to travel in a forward direction, the craft of the present invention will proceed in a forward direction in a substantially level position.

Referring now to FIGURE 15, a plan view illustrating a further embodiment having an elevation view similar to that shown in FIGURE 13 is shown. In this embodiment, cargo or passenger space comprises a hollow annular or doughnut shaped enclosure 220 which surrounds the circular multi-deck antenna and lifting grid structure. The stabilization and guidance system may be the same as is illustrated in FIGURE 12, and flaps 208 and foil 206 on the upper and lower central surfaces of the craft as illustrated in FIGURE 13 are preferably used.

In this embodiment, the air draft extends over a sufficiently large area so that the craft is no longer supported solely by the reaction or momentum of the air, but a high pressure wave created beneath the craft to support it in a manner which is similar to that by which a parachute is supported. This will add further to the efficiency which can be expected from the large sized craft of the present invention.

From the foregoing, it is apparent that the craft of the present invention is of simple construction and that small designs can serve as test vehicles of different designs and as toys operated from fixed power supplies through flexible lightweight leads. Because of the high internal impedance inherent with high voltage power supplies as are used in commercial television receivers, in smaller models, as for example toy size, any shock that is received by a human is not fatal and accidental short circuits carry insufficient current to cause serious heating or fires.

Flying craft covering a horizontal area of several thousand square feet and containing their own power supplies will be particularly well adapted for industrial and military applications requiring hovering devices at altitudes up to at least 10,000 to 20,000 feet, such as for example, offshore radar and weather stations, oil drilling rigs and the like. In view of the extremely low amount of power and maintenance required for the craft to remain aloft, my improved craft may also be economically used for relatively slow commercial travel and for various other applications.

The invention may be embodied in other specific forms without departing from the spirit or essential charac-

teristics thereof. The present embodiments are therefore to be considered in all respects as illustrative and not restrictive, the scope of the invention being indicated by the appended claims rather than by the foregoing description, and all changes which come within the meaning and range of equivalency of the claims are therefore intended to be embraced therein.

What is claimed and desired to be secured by United States Letters Patent is:

1. A method of propelling flying apparatus having a light weight skeleton construction encompassing a large relatively open area comprising the steps of imparting low velocity to air downwardly through said area by means of the application of a controlled high voltage field between two portions of said skeleton vertically disposed relative to one another to provide a low ion current discharge resulting in elastic molecular and particle collision throughout said electric field to lift said apparatus and varying the electric field in different portions of said skeleton to independently control the air velocity in separate regions of said area to stabilize and guide the apparatus while lifted.

2. A method of propelling flying apparatus comprising the steps of imparting a low velocity to air by an electrical discharge causing molecular and particle collisions through said apparatus over an open grid of conducting material having a large surface area generally in a plane transverse of the direction of the air velocity, and independently controlling the air velocity in separate regions of said area to stabilize and guide said apparatus while flying through variation of the rate of electrical discharge in said separate regions.

3. Flying apparatus comprising: a lightweight, relatively open lifting grid composed of crossed wires of conductive material disposed substantially in a plane; antenna means; means for supporting said antenna means in a plane substantially parallel to the grid plane to be substantially equidistantly spaced above and from said lifting grid so as to avoid concentrated electrical discharge when energized, and means for supplying an electrical energizing potential between said antenna means and said lifting grid to cause said apparatus to rise in a direction perpendicular to the grid plane into space as a result of ionic discharge inducing elastic particle collision in the space between said antenna means and said lifting grid.

4. A thrust producing device comprising: a base composed of frame members and means forming an open crossed wire grid composed of conducting material disposed substantially in a plane; antenna means; means for supporting said antenna means in a plane substantially parallel to the plane of the grid and spaced therefrom to be in an electrically insulated manner from said grid of conducting material in the atmosphere; means for supplying an electrical potential between said antenna means and said grid of conducting material to cause air flow in a direction from the antenna means to said grid resulting from particle collision caused by the ionic discharge from said antenna in the electric field between the antenna means and grid.

5. The device as defined in claim 4 wherein said antenna means comprises a plurality of non-intersecting wires supported so as to avoid concentrated discharge to said grid wires.

6. In a thrust producing device comprising a grid of conductive material and antenna means comprising a plurality of non-intersecting wires supported at a spaced position from said grid with tension so as to avoid concentrated electrical discharge therebetween, the improvement comprising light weight air deflecting means between said non-intersecting antenna wires for directing air flow across said antenna wires to urge ionized particles in the vicinity of said antenna wires toward said grid.

7. In a thrust producing device comprising a grid of conductive material and antenna means comprising a plurality of non-intersecting wires supported at a spaced

position from said grid with tension so as to avoid concentrated electrical discharge therebetween, the improvement comprising electrical conducting means supported between adjacent antenna wires and biased to a potential intermediate in value to that of said antenna wires and said grid to spread ionized particles in the space and reduce interfering electrical interaction between adjacent antenna wires.

8. In a thrust producing device comprising a grid of conductive material and antenna means comprising a plurality of non-intersecting wires supported at a spaced position from said grid with tension so as to avoid concentrated electrical discharge therebetween, the improvement comprising bias rods supported between adjacent antenna wires, the relative spacing of the bias rods between adjacent antenna wires and from the grid determining the effective potential on said bias rods to attract ions from and reduce interfering interaction between adjacent antenna wires, and the shape of said bias rods directing air flow across said antenna wires to urge ionized particles in the vicinity of said antenna wires toward said grid.

9. In combination with a source of high voltage electrical power, a heavier-than-air flying craft comprising a lifting grid connected to one terminal of said power source and formed so as to provide a substantially uniform electric field throughout the grid, antenna means comprising a plurality of wires connected to another terminal of said power supply and spaced to provide a non-uniform electric field to provide a device which is electrically asymmetrical, and means supporting said wires in a manner to facilitate vibration thereof while avoiding concentrated discharge therefrom to said lifting grid.

10. In combination with a source of high voltage electrical power, a heavier-than-air flying craft comprising a lifting grid connected to one terminal of said power source and formed so as to provide a substantially uniform electric field throughout the grid, antenna means comprising a plurality of wires connected to another terminal of said power supply and spaced to provide a non-uniform electric field to provide a device which is electrically asymmetrical, and conductor means spaced between adjacent ones of said wires and provided with an electrical potential intermediate that of said wires and said grid to spread ionized particles adjacent said wires over the space between said wires at a position spaced from said wires toward said grid.

11. The combination as defined in claim 10 wherein said conductor means have a width of approximately $\frac{1}{4}$ of the spacing between adjacent ones of said wires and are contoured and positioned so as to concentrate air flow across said wires to thereby facilitate removal of charged particles from said wires.

12. In combination with a source of high voltage electrical power, a heavier-than-air flying craft comprising antenna means connected to one terminal of said power source, large area lifting grid means separated into a plurality of electrically insulated regions for providing a substantially uniform electric field throughout each region, and conductor means from each of the regions of said lifting grids connected to another terminal of said source and including means for varying the electrical impedance to selectively control the potential applied between said antenna means and each of said regions.

13. The combination as defined in claim 12 wherein said means for varying the electrical impedance comprises manually operable means for controlling a spark gap.

14. The combination as defined in claim 13 wherein said manually operable means includes a first control element for producing a difference in the potential applied to the fore and aft regions, and a second control element for producing a difference in the potential applied to the right side and left side regions.

15. In combination with a source of high voltage elec-

trical power, a heavier-than-air flying craft comprising a plurality of lifting decks stacked one on top of the other, each of said decks comprising an open lifting grid formed so as to provide a substantially uniform electric field throughout the grid, antenna means supported above its associated lifting grid for providing a non-uniform electric field to provide a device which is electrically asymmetrical, and means for connecting the antenna means and said lifting grids of each deck to opposite terminals of said power supply.

16. In combination with a source of high voltage electrical power, a heavier-than-air flying craft comprising a plurality of lifting decks stacked one on top of the other, each of said decks comprising an open lifting grid formed so as to provide a substantially uniform electric field throughout the grid, antenna means supported above its associated lifting grid for providing a non-uniform electric field to provided a device which is electrically asymmetrical, and means for connecting the antenna means and said lifting grid of each deck to opposite terminals of said power supply with the lifting grid next above each antenna means connected to the same power supply terminal whereby positive and negative ions are used in alternate decks of said craft.

17. In combination with a source of high voltage electrical power, a heavier-than-air flying craft comprising a lightweight lifting grid of non-rigid spaced electrical conductors extending over a large area and having structural members to support said conductors, said structural members being oriented in a planar honeycomb arrangement to provide maximum rigidity per unit of weight, said grid providing a substantially uniform electric field and having associated therewith antenna means lying in a plane substantially parallel to the honeycomb plane for providing a non-uniform electric field in atmosphere, and means for connecting said grid and said antenna means to opposite terminals of said power source.

18. In combination with a source of high voltage electrical power, a heavier-than-air craft comprising a lightweight lifting grid extending over a large area and having members oriented in an arrangement to provide a high rigidity per unit of weight ratio, said grid providing a substantially uniform electric field and having associated therewith antenna means for providing a non-uniform electric field, means for connecting said grid and said antenna means to opposite terminals of said power source, and an air foil on the top and bottom surfaces of said craft having streamlined flaps hinged at one edge thereof.

19. The combination as defined in claim 18 wherein a peripheral air foil surrounds said lifting grid thereby creating a high pressure wave beneath the craft to further increase the lifting efficiency thereof.

20. In an aircraft having a central vertical opening surrounded by walls, means including a high voltage electric field for propelling said craft by momentum caused by molecular and particle collision with ions directed downwardly through said vertical opening in the presence of said electric field, and means including an air foil on at least the lower portion of said walls to create a high pressure wave beneath the aircraft.

21. A method of propelling flying apparatus capable of rising vertically comprising a lightweight, open lifting grid of conducting material which has a peripheral structure member lying substantially in a plane and antenna means spaced a uniform distance from said grid, said method comprising: accelerating large masses of air to relatively low velocities in a direction substantially normal to said plane by application of a high voltage, low current electrical potential between said antenna means and said open grid to cause air flow through said grid, and controlling the voltage to cause ionic discharge in a direction normal to said plane resulting in elastic molecular and particle collision while avoiding

secondary ionization in the region between said antenna means and said lifting grid.

22. A method of generating thrust from apparatus embodying antenna means, a relatively open grid of conducting material lying generally in a plane and the conducting material being substantially equidistantly spaced from said antenna means, and a high voltage supply of electrical power therefore; the method comprising the steps of ionizing the air particles adjacent said antenna means; attracting said ionized particles from the region of said antenna means toward and through said open grid by application of high voltage from said power supply; and controlling the voltage applied between said antenna means and open grid to cause elastic particle collision in air at substantially atmospheric pressure in the space between said antenna means and said open grid for developing thrust.

23. In combination with a source of high voltage electrical power, a heavier-than-air craft composed of a plurality of decks stacked one on top of the other with each deck comprising a lightweight lifting grid of non-rigid spaced electrical conductors extending over a large area and having structural members oriented in a planar honeycomb arrangement to provide maximum rigidity per unit of weight, said grid providing a substantially uniform electric field; and antenna means associated with and uniformly spaced from said grid in a direction perpendicular to said honeycomb plane, said antenna means providing a non-uniform electric field in air at atmospheric pressure; and means for connecting said grid and said antenna means to opposite terminals of said power source.

24. In combination with a source of high voltage electrical power, apparatus comprising a grid composed of non-rigid spaced electrically conducting wire-like members extending over a large area and having structural means oriented to provide a rigid frame surrounding said large area and carrying said wire-like members substantially in a plane; antenna means; means connecting said grid and said antenna means to opposite terminals on said power source to produce charged particles at said antenna means; and means positioning the antenna means for causing said charged particles to pass along a path from the antenna means toward said plane that is angularly related to said plane and extends through the space between said wire-like members.

25. Apparatus for thrust generation having a large open area, the peripheral defining portions of said area lying substantially in a plane, and further comprising means for creating thrust on said peripheral defining portions in a direction normal to said plane by acceleration of large masses of air through said open area in a direction normal to said plane including means for applying a controlled high voltage between the open area of said plane and a region spaced in a direction normal to said plane, means in the open area of said plane for providing a substantially uniform electric field potential throughout said open area, means in said region for producing a non-uniform electric field potential and an ion current discharge, said thrust arising from elastic molecular and particle collision throughout said high voltage electric field.

26. Apparatus for generating thrust having a large, laterally extending open area, the peripheral portions of which are substantially in a plane, and comprising means for creating thrust in a direction normal to said plane by acceleration of large masses of air to relatively low velocities through said area in a direction normal to said plane including antenna means for producing charged particles, means in the open area of said plane for providing a substantially uniform electric field potential throughout said open area, and means for providing an electric field for attracting ionized particles of said air predominantly from one side of and toward said plane.

27. In apparatus for thrust generation in atmosphere,

15

composed of spaced electrodes energized with a voltage sufficiently high to be capable of causing ionization for effecting an ionic discharge from an emitting electrode to produce thrust on at least one of the electrodes of said apparatus arising from elastic molecular and particle collisions occurring in the space between said electrodes during molecule and particle movement in the direction from the emitting electrode to the collecting electrode, the improvement wherein said collecting electrode is composed of crossed grid wires of conductive material forming an open surface that is generally normal to the direction of molecule and particle movement.

References Cited in the file of this patent

UNITED STATES PATENTS

1,802,860 Zwinkel ----- Apr. 28, 1931

1,907,160
1,974,483
2,309,584
2,460,175
2,556,982
2,585,810
2,587,173
2,636,664
2,755,014
2,765,975
2,766,582
2,801,058
2,876,965
2,888,189
2,949,550

5

10

15

16

Schauman ----- May 2, 1933
Brown ----- Sept. 25, 1934
George ----- Jan. 26, 1943
Hergenrother ----- Jan. 25, 1949
Roos ----- June 12, 1951
Mallinckrodt ----- Feb. 12, 1952
Landgraft ----- Feb. 26, 1952
Hertzler ----- Apr. 28, 1953
Westendorp et al. ----- July 17, 1956
Lindenblad ----- Oct. 9, 1956
Smith ----- Oct. 16, 1956
Lent ----- July 30, 1957
Streib ----- Mar. 10, 1959
Herb ----- May 26, 1959
Brown ----- Aug. 16, 1960